

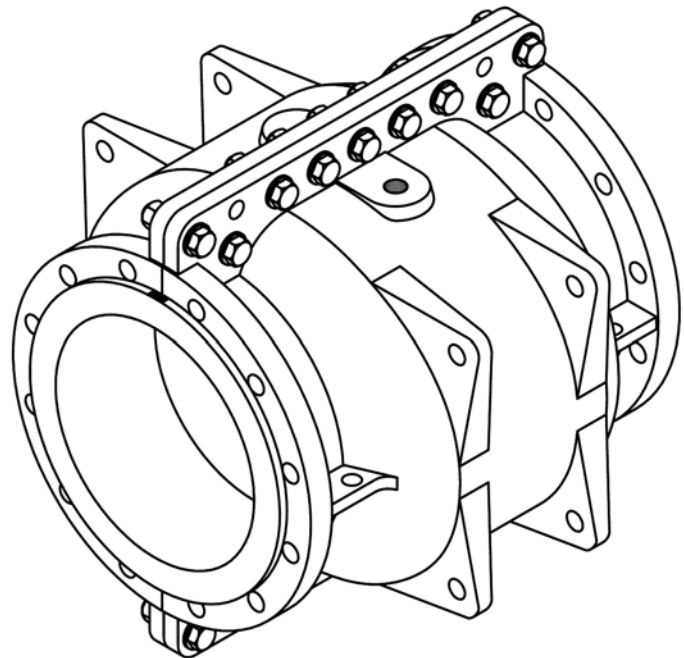

**TYPE (BSA) SEALED VALVE BODY**  
**Series 2002**

***aiRFlex***<sup>®</sup>

**INSTALLATION, OPERATION AND  
MAINTENANCE MANUAL  
BS14 to BS20**



**CUSTOMER SERVICE HOT-LINE**  
**1-410-850-4404**

© 1998-2013 by RF Valves, Inc.

## CONTENT

|   |        |
|---|--------|
| <b>1.0 Introducing the aiRFlex® Valve</b> | Page 3 |
| 1.1 Operating Principles                  | Page 3 |
| <b>2.0 Installation</b>                   | Page 4 |
| 2.1 Inspection before Installation        | Page 4 |
| 2.2 Installation to the Pipeline          | Page 5 |
| 2.3 Air Supply Recommendations            | Page 5 |
| 2.4 Air Supply Pressure Requirements      | Page 6 |
| <b>3.0 Operation</b>                      | Page 7 |
| <b>4.0 Maintenance</b>                    | Page 8 |
| 4.1 Removing the Elastomer Tube           | Page 8 |
| 4.2 Installing the Elastomer Tube         | Page 8 |
| 4.3 Installing the Gasket Seal            | Page 9 |

## **1.0 INTRODUCING aiRFlex® VALVE**

This manual covers the installation, operation, and maintenance of the aiRFlex® air actuated valve.

### **1.1 Operating Principles**

The air actuated valve features an elastomer tube inside a sealed valve body (see figure 1). When the interior of the valve body is pressurized 30psi greater than the pressure inside the elastomer tube, the tube collapses and stops the flow of media through the valve. MINIMUM PLANT AIR PRESSURE REQUIRED TO OPERATE VALVE IS 50 PSI, UNLESS OTHERWISE SPECIFIED. Relieving the pressure inside the sealed valve body causes the tube to spring back fully opened, thus allowing flow of media through the valve.

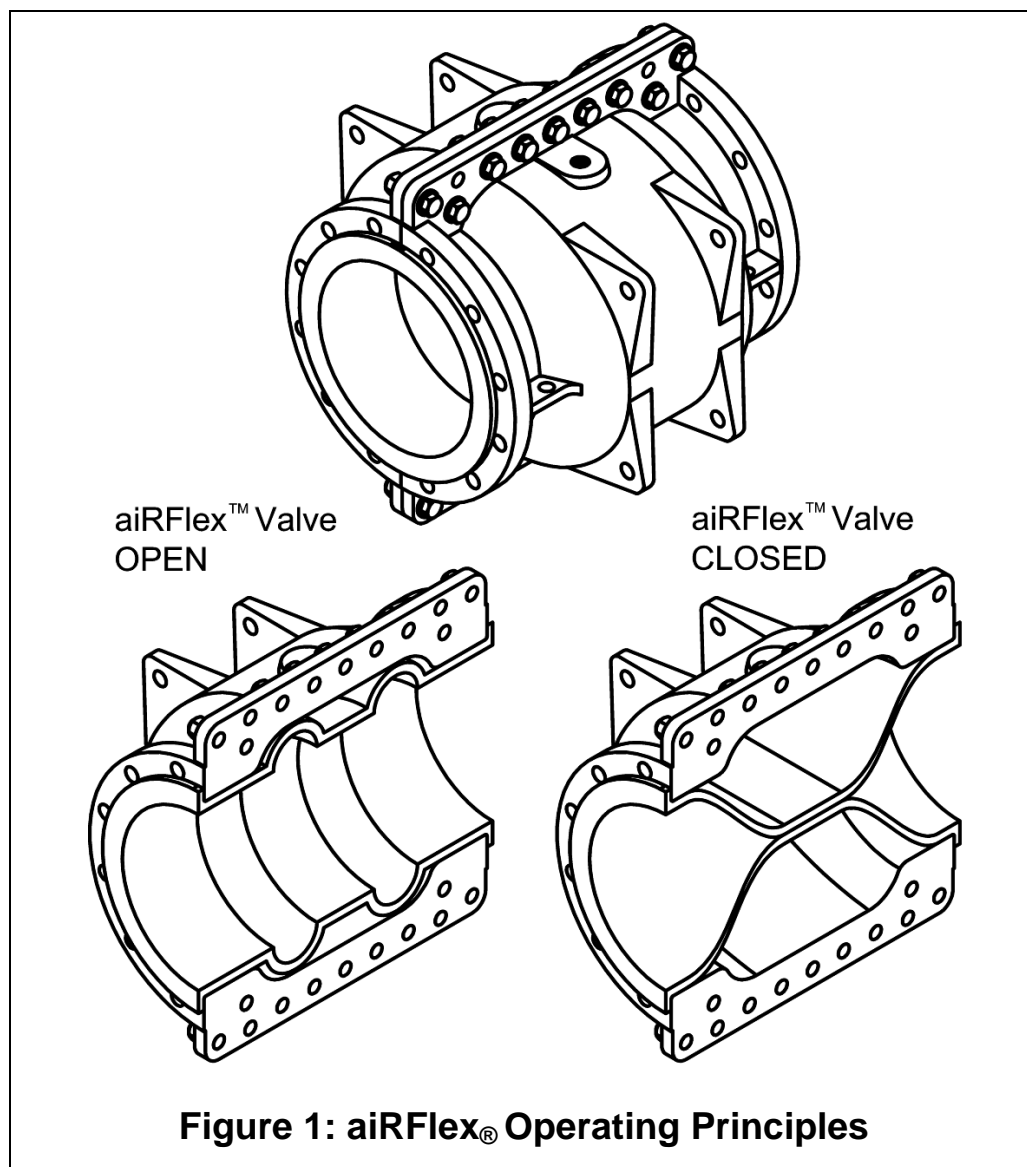

## 2.0 INSTALLATION

Proper installation of the aiRFlex® valve will maximize the life of the elastomer tube. Incorrect installation procedures may not only reduce the lifetime of the elastomer tube but may cause the aiRFlex® valve to not operate at all.

### 2.1 Inspection Before Installation

The aiRFlex® valve, when new, has a PTFE gasket in between the valve body halves in side the body bolt hole pattern:

- 1) Yellow marks on outside flange of the elastomer tube line up within 5 degrees of the valve body split.
- 2) For installation onto a horizontal pipeline, be sure that the valve is installed with the split of the valve being vertical. However in a vertical pipeline, the aiRFlex® valve can be installed in any orientation (see figure 2-2).
- 3) If tube is worn and being replaced, go to Section 4.0 Maintenance

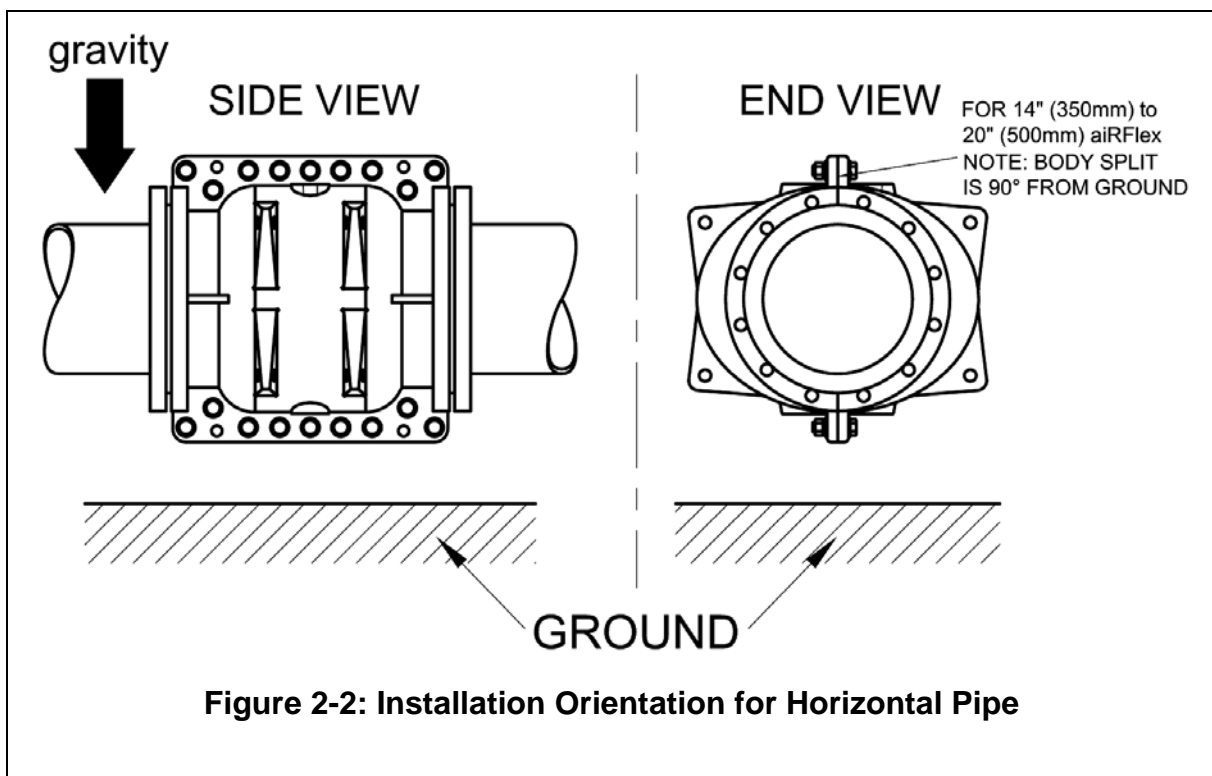
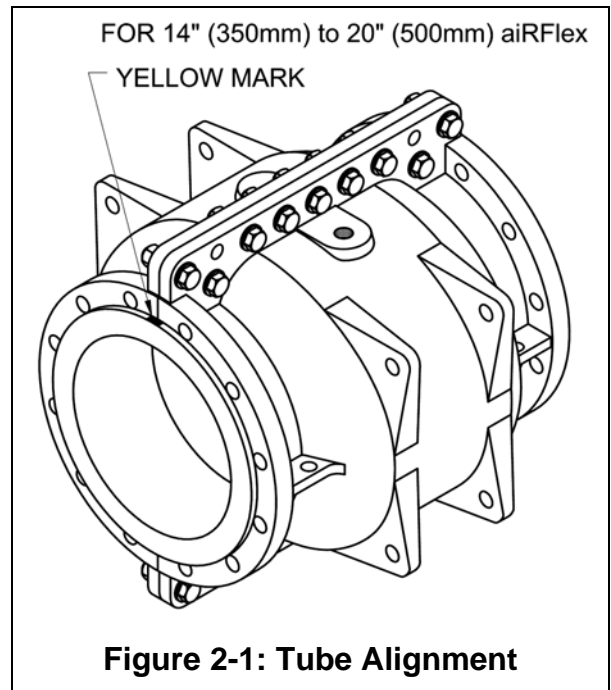

## 2.2 Installation to the Pipeline

aiRFlex® valves are bi-directional flow capable unless it is of reduced port type. For reduced port aiRFlex® valve the inlet side is greater than the outlet side. Install the aiRFlex® valve so that flow goes from inlet to outlet. Note that a stainless steel arrow riveted to the valve body also indicates flow direction. See figure 2-3.

**STEP 1:** Pipe flanges must be measured to insure they are parallel (see figure 2-3), maximum deviation from parallel  $A-B \leq 0.031$ ". NOTE: Tightening bolts when flanges are NOT PARALLEL can cause damage and possible failure of the elastomer tube that serves as a gasket between the valve body and the pipe flanges.

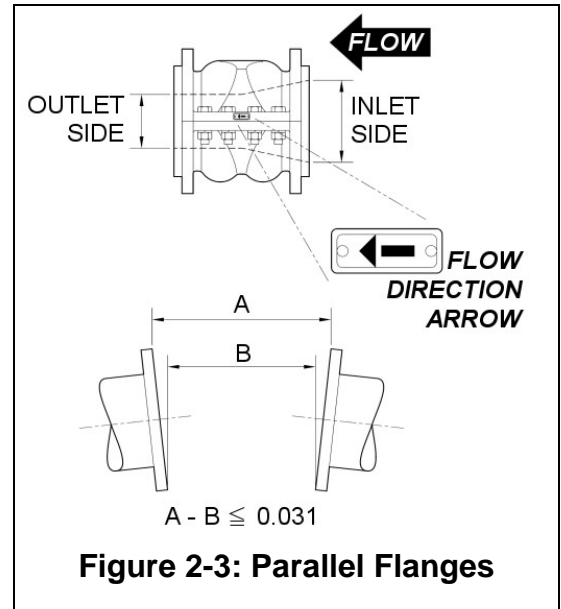

**STEP 2:** Torque all flange bolts in a star pattern; first to 50% of recommended values (ft·lbs) and then retorqued to 100% of recommended values (see table 1). Repeat star pattern torque procedure 3 to 4 additional times at 100% torque values to finalize flange seals.

**Table 1. ANSI #150 Recommended Flange Bolt Torque Specifications**

| VALVE SIZE | NO. OF BOLTS | BOLT CIRCLE DIA. | THREAD SIZE  | BOLT TORQUE (FT·LBS) |
|------------|--------------|------------------|--------------|----------------------|
| 14"        | 12           | 18 ¾"            | 1"-8 UNC     | 50                   |
| 16"        | 16           | 21 ¼"            | 1"-8 UNC     | 50                   |
| 18"        | 16           | 22 ¾"            | 1-1/8"-7 UNC | 50                   |
| 20"        | 20           | 25               | 1-1/8"-7 UNC | 50                   |

**2.3 Air Supply Recommendations - WARNING: AIR SUPPLY MUST BE REGULATED TO NEVER EXCEED 80 PSI. FAILURE TO DO SO CAN CAUSE PREMATURE TUBE FAILURE.** For best operation of the aiRFlex® valve, it is recommended that the air supply should be clean, dry, and non-lubricated.

**WARNING:** The oils in a lubricated air supply line may attack the elastomer so they should never be used with aiRFlex® valves.

## 2.4 Air Supply Pressure Requirements

To maximize the lifetime of the elastomer tube inside the aiRFlex® valve, the pressure in the air supply line should be regulated based on the graph below, **MINIMUM 50 PSI. PLANT AIR TO OPERATE.** Too little pressure and the aiRFlex® valve will not seal causing excessive wear to the elastomer tube. Too much pressure and the elastomer tube will be over-stressed. **IT IS BEST TO “TRAIN” THE ELASTOMER TUBE BY ACTUATING IT 3-5 TIMES BEFORE PLACING THE VALVE INTO SERVICE.** Please contact RF Technologies, Inc. to confirm requirements of valves being installed at Customer Service:

**TEL: 410-309-1029.** Have Valve ID No. ready for Reference.

### aiRFlex Pressure Requirements

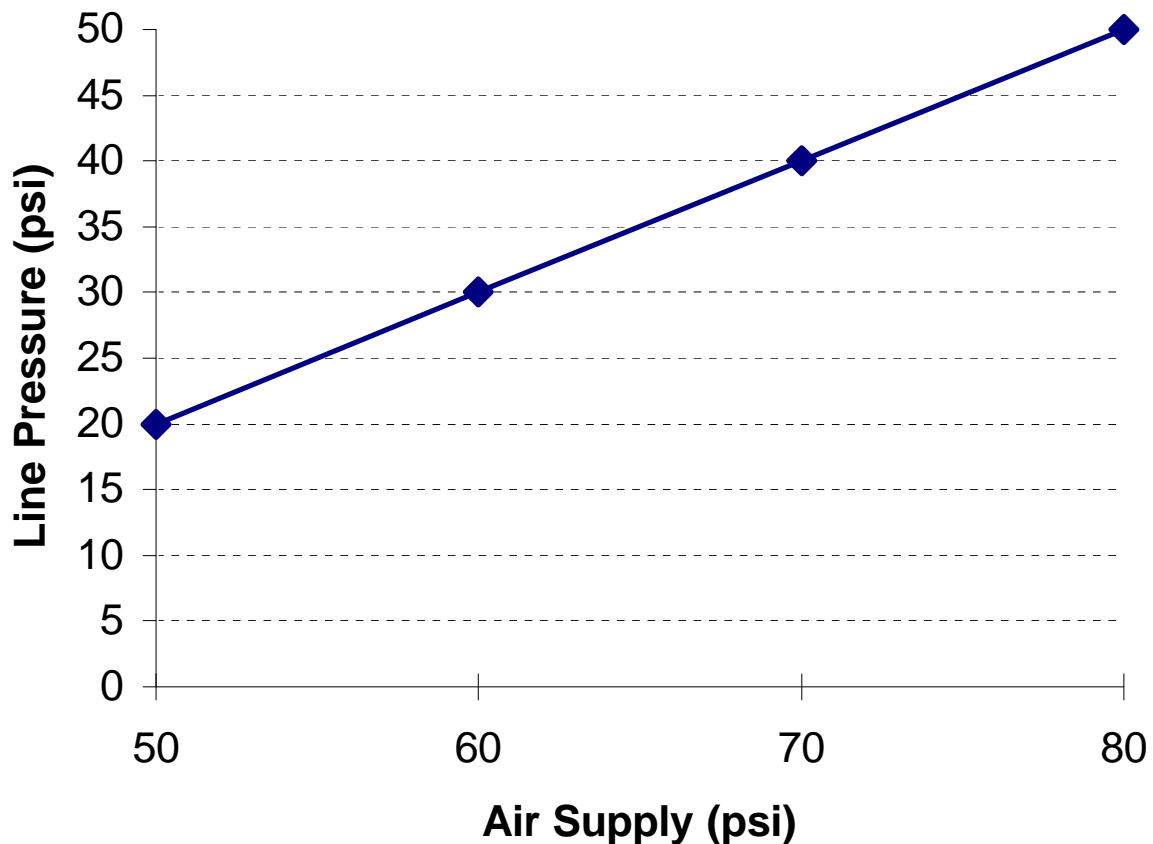

### 3.0 OPERATION

Once the aiRFlex® valve has been properly installed, it is ready for operation. A simple 3-way air valve is all that is needed to operate the aiRFlex® valve. Refer to figure 3-1 below for a sample pneumatic circuit to operate the aiRFlex® valve.

#### To close the aiRFlex® valve:

pressurize the inside of the valve body based on the graph found in section 2.4.

#### To open the aiRFlex® valve:

exhaust the air inside the valve body.

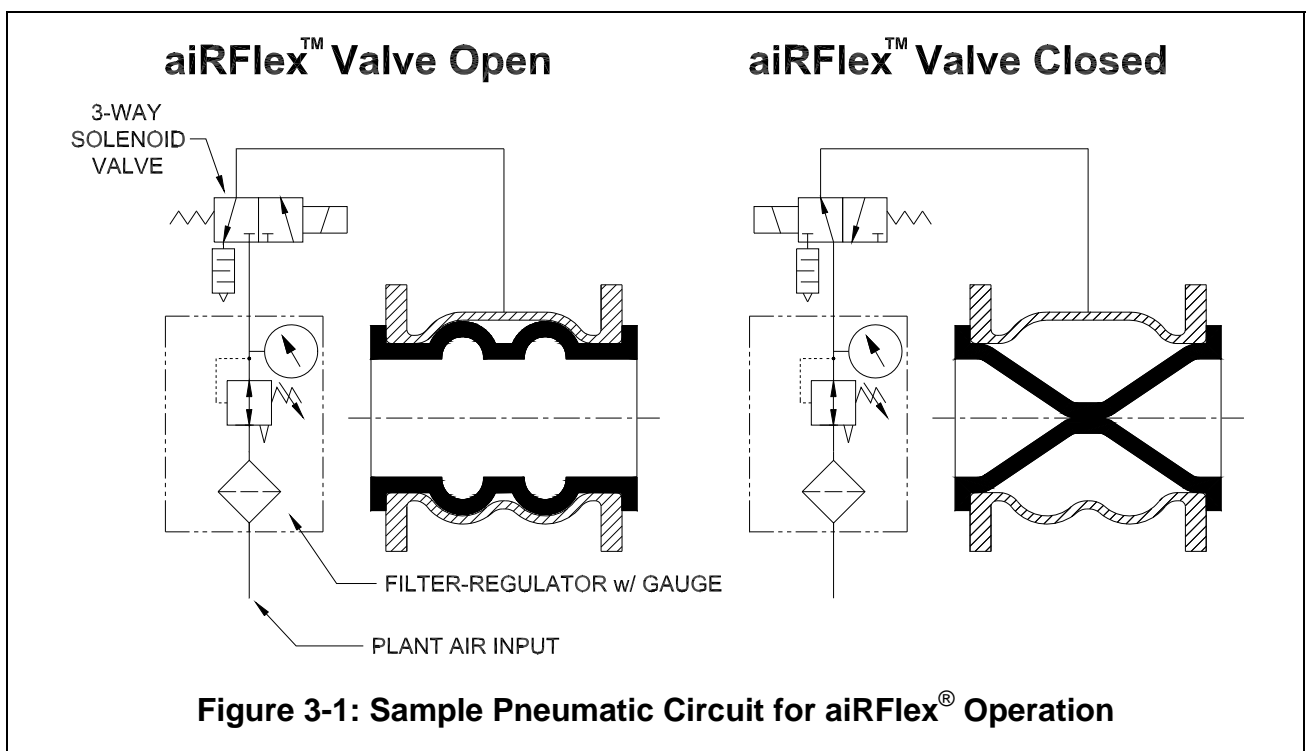

It is always a good practice to confirm plant air requirement for a given service by contacting Technologies, Inc. Customer Service to insure elastomer tube life is optimized in every service.

**TEL: 410-309-1029. Have aiRFlex® valve ID No. ready for Reference.**

## **4.0 MAINTENANCE**

Maintenance of the aiRFlex® valve involves changing the elastomer tube or changing the gasket between the valve body halves. A unique feature of the aiRFlex® valve is that all these maintenance procedures can be done without removing the aiRFlex® valve from the pipeline. Instructions below are for performing these maintenance tasks without removing the valve from the pipeline.

### **4.1 Removing the Elastomer Tube**

**STEP 1:** Disconnect the air supply from the aiRFlex® valve.

**STEP 2:** Loosen (but do not remove) the flange bolts until they are hand-tight.

**STEP 3:** Remove the flange bolts from the lower valve body only.

**STEP 4:** Remove the bolts that secure the aiRFlex® valve body halves together and remove the lower valve body.

**STEP 5:** The elastomer tube should be free enough to be removed.

### **4.2 Installing the Elastomer Tube**

**STEP 1:** Verify that the elastomer tube has **YELLOW** marks on the outer edge of the elastomer tube flanges.

**STEP 2:** Verify that the gasket seal between the valve body halves is intact. If not, proceed to section 4.3 to install a new gasket seal. It is good general practice to change it.

**STEP 3:** Insert the elastomer tube inside one of the halves of the aiRFlex® valve. Be sure that the **YELLOW** marks line up within 5 degrees of the split of the valve body.

**STEP 4:** Bring the valve body halves together. Fasten the halves together evenly with bolts, nuts, and lock washers. To get a good seal between the valve body halves, the nuts and bolts should be tightened equally. If valve body is aluminum, use flat washers.

**STEP 5:** Insert flange bolts into the lower half of the aiRFlex® valve body.

**STEP 6:** Torque the flange bolts as instructed in section 2.2.

**STEP 7:** It is always recommended to test IF the valve body leaks before operation. Attach a flange to both sides of the valve, torque closed per torque instructions, and pressurize the valve to 50 psi. If leaking occur, apply additional torque to body fasteners in small increments. If leak persists, consider installing new gasket material, or re-applying gasket per instructions in Section 4.3 [Next Page].



**4.3 Installing the Gasket Seal**

**STEP 1:** Follow the steps in section 4.1 to disassemble the aiRFlex® valve and gain access to the gasket seal.

**STEP 2:** Remove the old seal from the valve body half. Afterwards, be sure that the surfaces of the valve body halves are clean and free of grease, oil, solvents, etc.

**STEP 3:** PTFE Teflon joint sealant gasket tape is sufficient to seal the valve body halves for many common sizes. Apply the tape to only one of the valve body halves, not both. The tape should follow the interior perimeter of the valve body half with a 1/8" extension beyond the body (see figure 4-1). Consult valve Bill of Material (BOM) for type and width, or from Table, below:

|            |                |             |          |        |
|------------|----------------|-------------|----------|--------|
|            | 1" – 1.5 inch. | 2" – 8 inch | 10 – 14" | 16" >  |
| PTFE Width | 1/8 inch       | ¼ inch      | ½ inch   | ½ inch |

Failure to utilize gasket & width recommended by RF Technologies, could result in leakage.

**STEP 4:** Follow the steps in section 4.2 to reassemble the aiRFlex® valve.

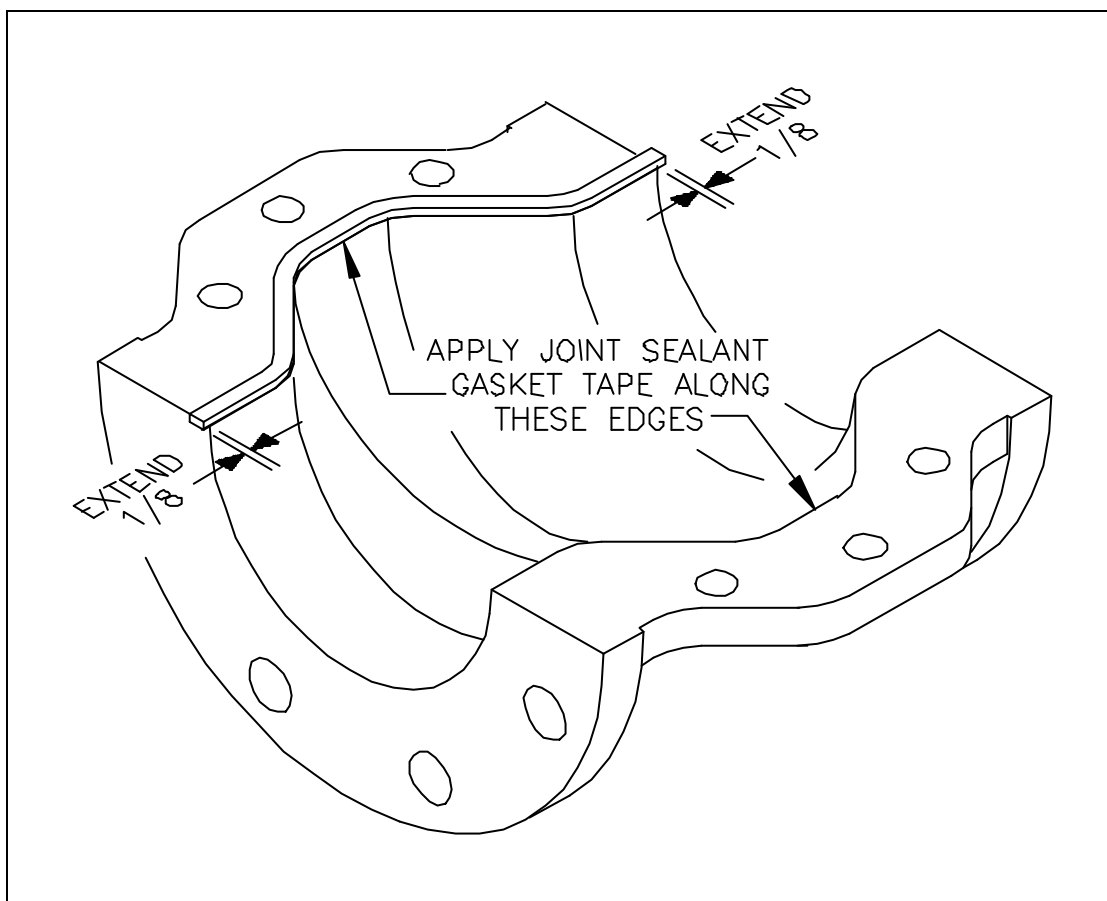

**Figure 4-1: Joint Sealant Gasket Tape Application**

## **APPENCICES**

- 1. Valve Data Sheets**
- 2. GA Drawings**
- 3. Bill of Materials**
- 4. Accessories**